



Product datasheet

Product name Separator with quick clamping pressure spindle
For removing ball bearings, roller bearings, inner races and other tight parts if there is not enough space to use pulling hooks.



Product number 17-3

Product series 17

EAN 4021176008443





Technical attributes

Attribute name	Attribute value
 Diameter of the shaft	25 - 155 mm (1 - 6 1/8 inch)
 distance of side screw	155 mm (6 1/8 inch)
 weight	7.1 kg

Spare part

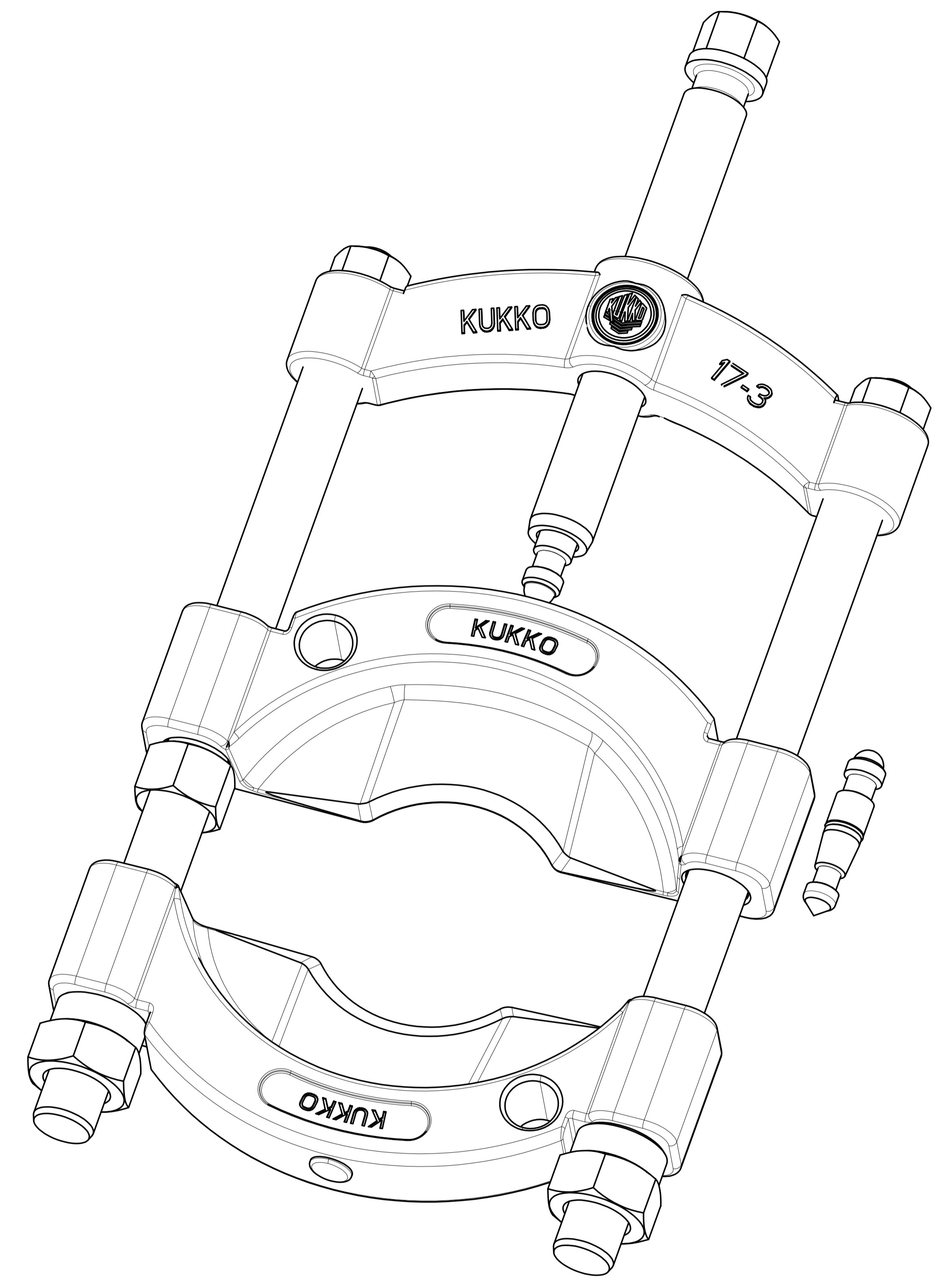
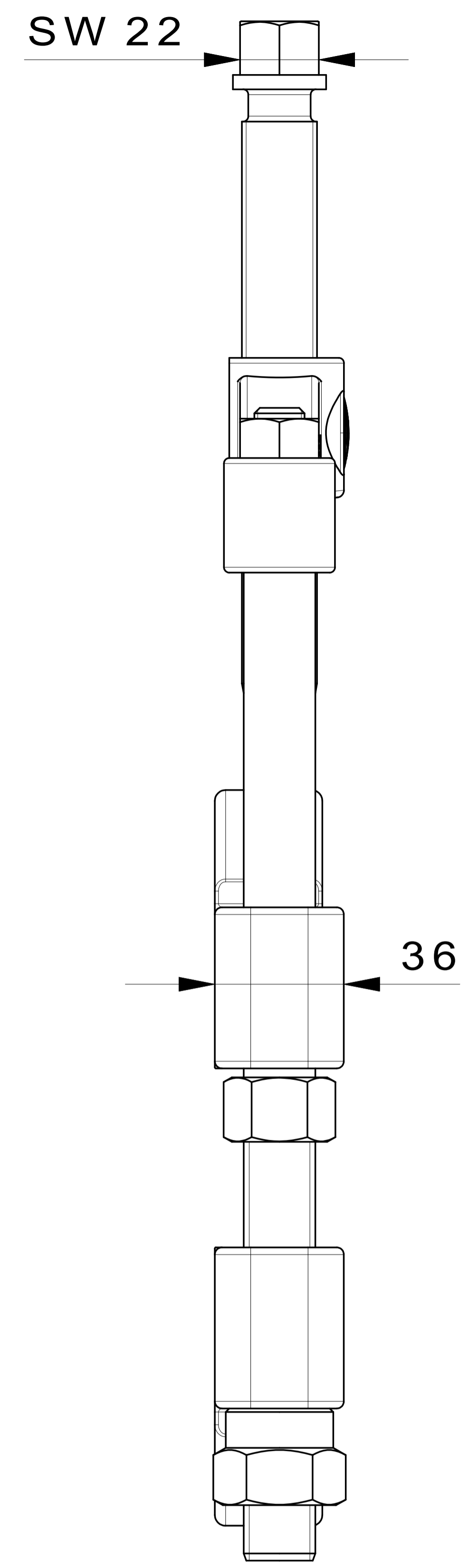
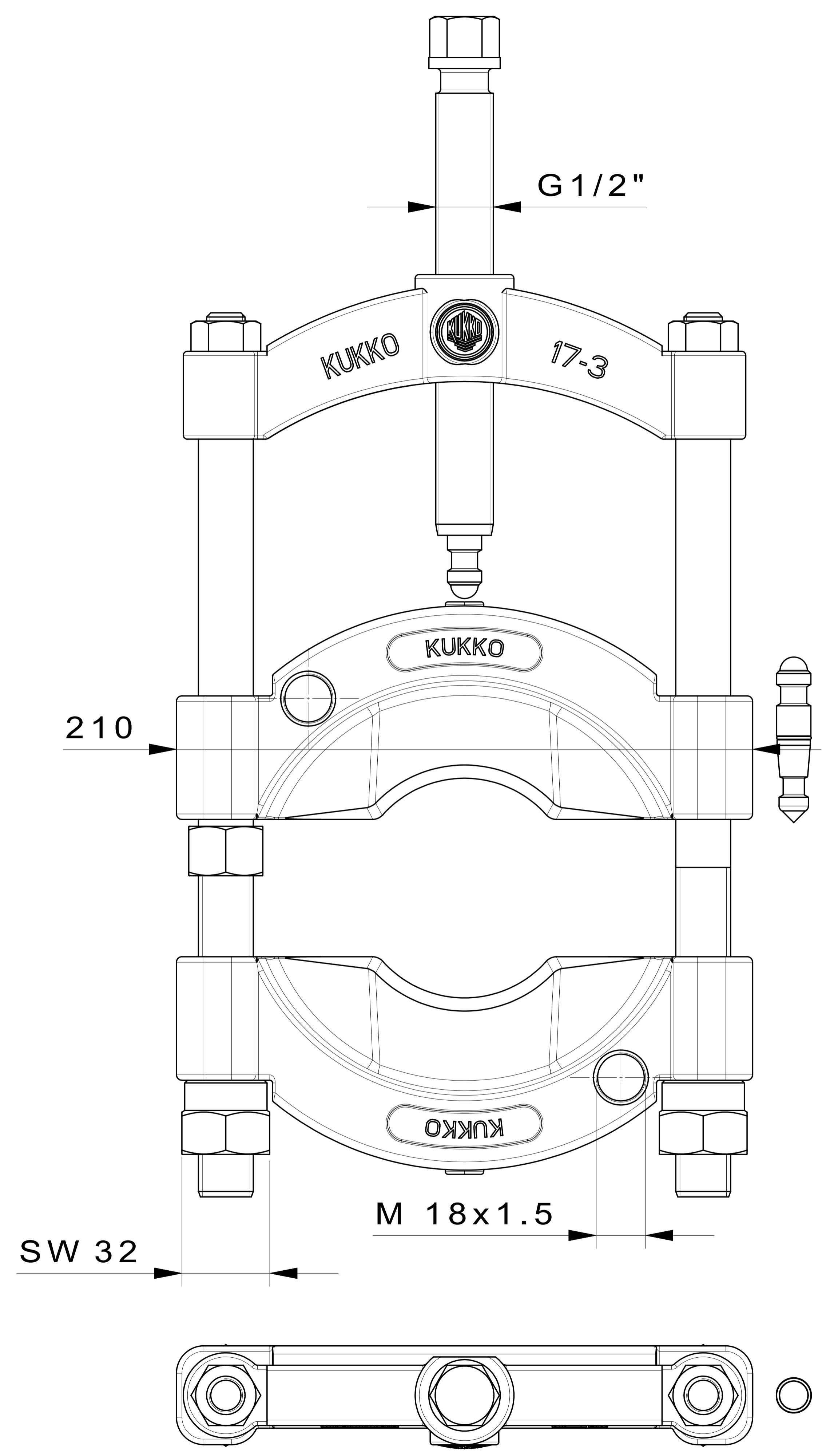
Product number	Product name
621220	Mechanical pressure spindle.
17-3-T	Cross-beam
17-3-06	Spindle
017322	Side bolt complete



 Kleinbongartz & Kaiser oHG Werkzeugfabrik Hilden - Germany	Dokumentname: 17-3_Trennvorrichtung mit Spindel	Toleranz: DIN ISO 2768-m
	Dokumentbeschreibung: Baugruppe	Material: Hoch legierter Werkzeugstahl / High alloy tool steel
Erstellt von: Schultes	Erstellungsdatum: 12/04/2016	Maßstab: 1:1
Teilbeschreibung: Trennvorrichtung mit Schnellspanndrucksindel/ Separator with quick clamping pressure spindle		Wärmebehandlung / Härte: vergüteter Stahl/ tempered steel Oberflächenbehandlung:
Artikelnummer / ZNR: 17-3	Dokumentversion: -	Schutzvermerk: ISO 16015 beachten