



# Product datasheet

**Product name** Separator with quick clamping pressure spindle  
For removing ball bearings, roller bearings, inner races and other tight parts if there is not enough space to use pulling hooks.



**Product number** 17-0

**Product series** 17

**EAN** 4021176008108





## Technical attributes

Attribute name	Attribute value
 Diameter of the shaft	8 - 60 mm (3/8 - 2 3/8 inch)
 distance of side screw	60 mm (2 3/8 inch)
 weight	1 kg

## Spare part

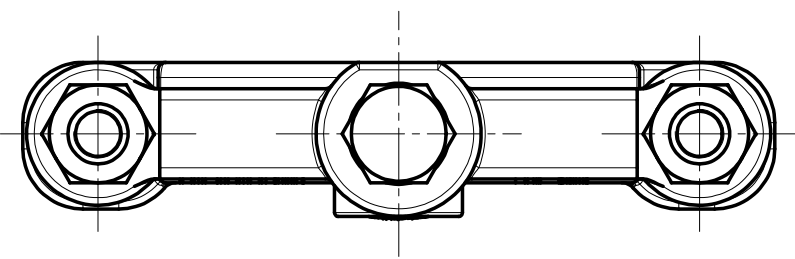
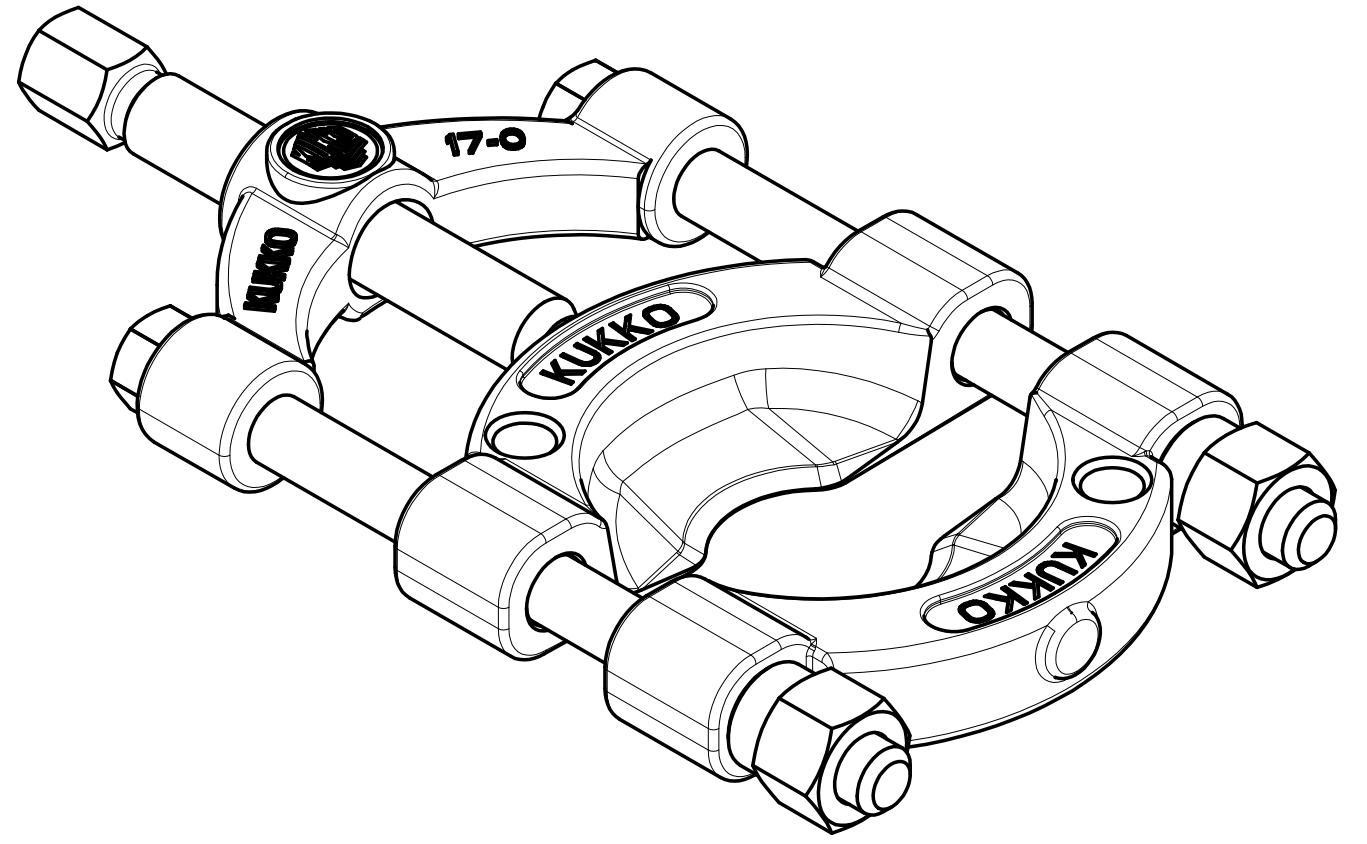
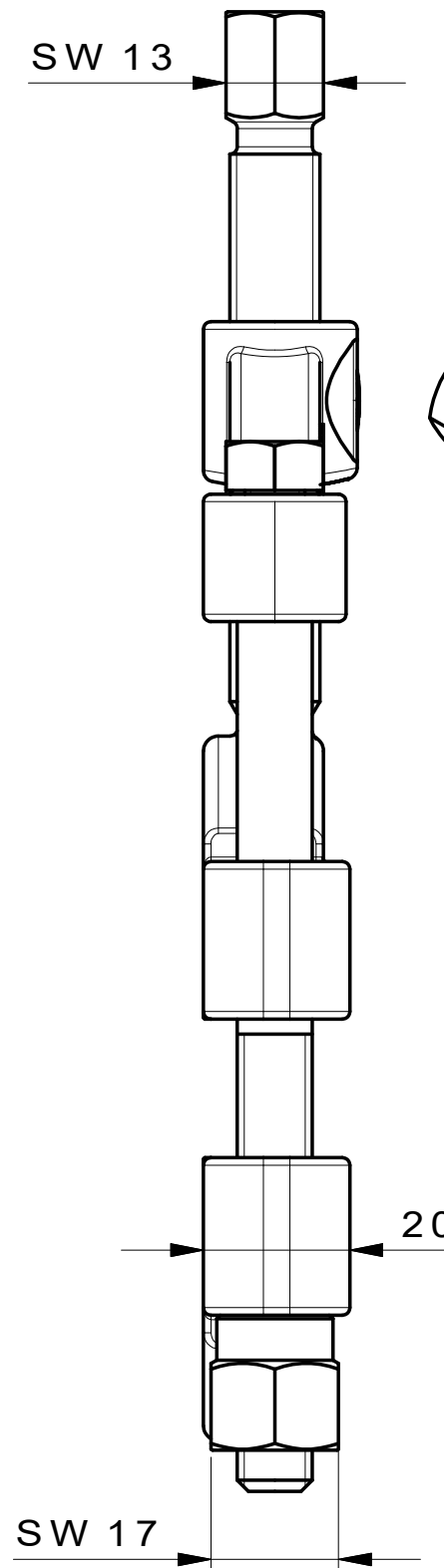
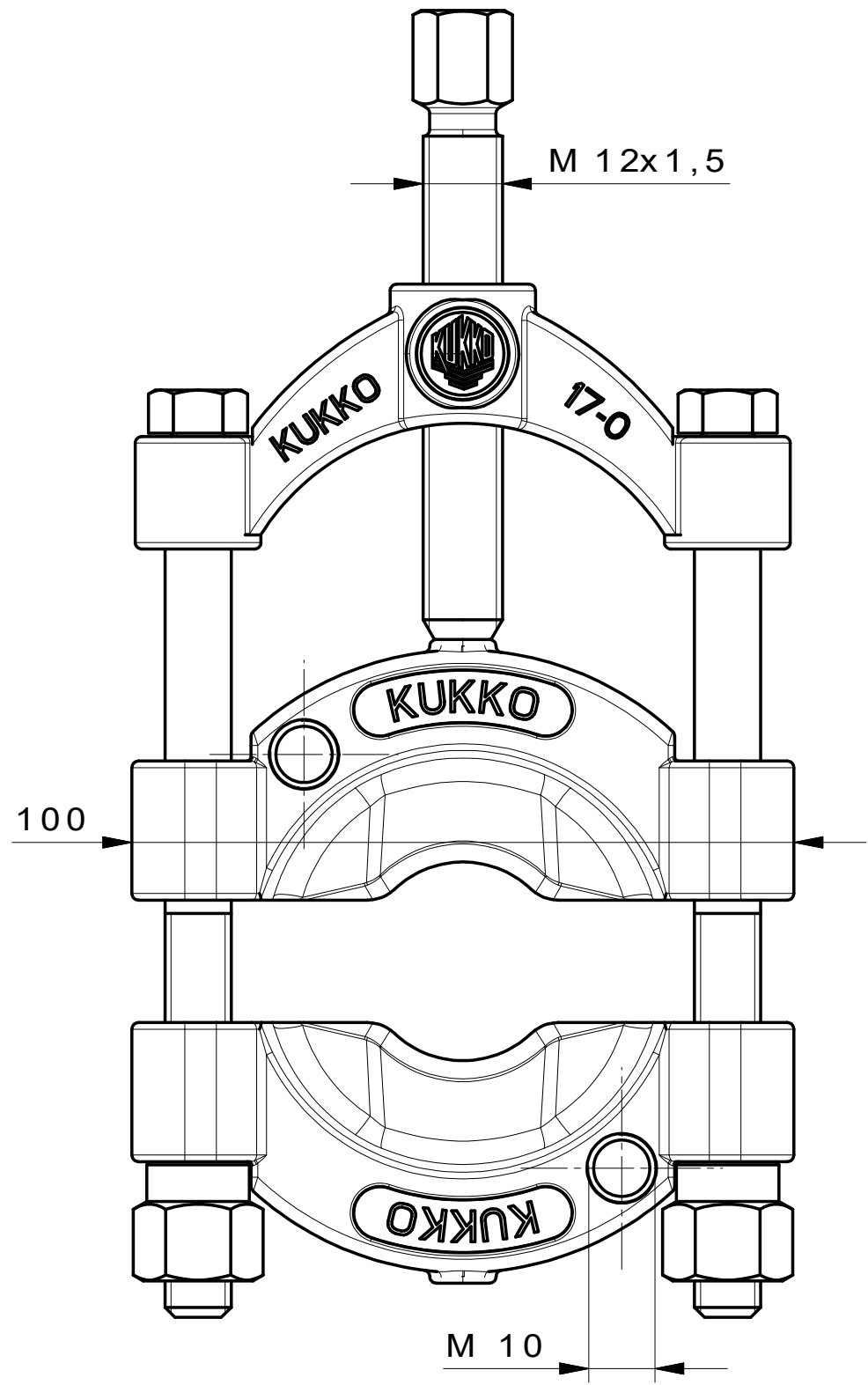
Product number	Product name
17-0-T	Cross-beam
17-0-06	Spindle
017140	Side bolt complete



 <b>Kleinbongartz &amp; Kaiser oHG</b> Werkzeugfabrik Hilden - Germany	Dokumentname: 17-0_Trennvorrichtung mit Spindel	Toleranz: DIN ISO 2768-m
	Dokumentbeschreibung: Baugruppe	Material: Hoch legierter Werkzeugstahl / High alloy tool steel
Erstellt von: Schultes	Erstellungsdatum: 11/04/2016	Maßstab: 1:1
Teilbeschreibung: Trennvorrichtung mit Schnellspanndruckspindel/ Separator with quick clamping pressure spindle		Wärmebehandlung / Härte: vergüteter Stahl/ tempered steel
Artikelnummer / ZNR.: 17-0	Dokumentversion: -	Schutzvermerk ISO 16016 beachten
Oberflächenbehandlung:		